



Yemeni-German Development Cooperation
in the Water & Sanitation Sector
Poverty Relevance of Urban Interventions
(Gerhard Redecker, KfW-Office Sana'a)



In order to verify the poverty relevance of its more recent urban interventions in water and sanitation systems, KfW has conducted project specific baseline surveys in 8 towns during 2002 and 2004. The final results of the 2002 survey (PTP II towns) and preliminary data of the 2004 data have been compiled in this document. The towns covered were Jiblah, Ja'ar/Zinjibar, Al Shaheer (2002 and Zabid, Sa'ada, Amran and Ibb (2004).

For the poverty analysis related to water tariffs, GTZ has provided data collected from a number of additional utilities attended in the framework of the water sector support project.

The President of the Republic inaugurates the Amran Water and Sanitation Project, in 2004.



Fetching water from municipal in Thula, 2004

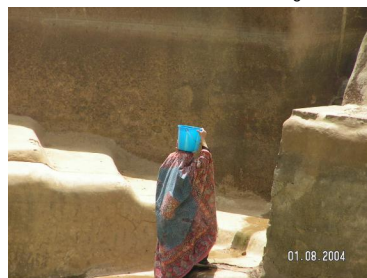

Table of contents

Poverty definition and relevant national data

Summary of conclusions

Sector salient features

- Water users and the MDG relevance
- Water demand and health impact
- Understanding Yemen's water cycle
- Expected urban growth
- Water demand and supply pattern
- Real cost of water and the Yemeni scenario
- Water sector benchmarks

Poverty indicators of survey towns

- Poverty profile of survey towns
- Household expenditure pattern
- Average household income
- Per capita food poverty line
- Income quintiles and water expenditure
- Sources and cost of water

Utility operators and pro-poor water tariffs

- Client base of utilities
- Consumption structure of utilities
- Range of prevailing lifeline tariffs
- Water tariffs and pro-poor cross subsidy potential

Technology choices

- Pro-poor choices for water supply
- Pro-poor choices for sanitation
- Results of study 1 (Ecosan)
- Results of study 2 (Alternative Sanitation Systems)

Relevance of urban sub-sector

- Urban share in NWSSIP
- Urban share in MDG needs assessment

Remarks and open questions

- Pro-poor project targeting
- Implementation constraints
- Recurrent costs

Poverty definition and relevant national data

The 2005 Household Budget Survey (HBS) is presently under implementation with financial participation of the German side. Results are not expected before 2006.

Data on poverty situation vary throughout the numerous socio-economic assessment reports. The 1998 HBS indicated that about 2 thirds of the Yemeni population were to be considered poor, with an overall expenditure not exceeding US\$ 1.50 per capita/day (PPP conversion). While mass poverty was higher in rural areas (70%), still 58% of urban population were affected by poverty. Using the US\$1.00/capita/day criterion, about 42% of all Yemenis were to be considered poor. In 2003, about 27% of the population lived below the food poverty line (expenditure needed for procuring the minimum of 2200 calories per day) at the national level.

The recent UNDP assessment on macro-economic policies takes up these statistics, stating, for 1998, "...headcount poverty in rural areas at 45.0% (lower poverty line) and 66.9% (upper poverty line), while the corresponding values for urban areas were 30.8% and 57.8%, respectively. The "upper poverty" line is defined as the value of the basket of goods and services that is actually consumed by the households whose food and energy intake is equal to the minimum requirement of 2.200 calories per person per day. At the official exchange rate this poverty translates into about US\$ 1.1 per day, and the 19985 PPP rate is about US\$ 1.5 per day. In other words, in 1998 69.6% of the rural and 57.8% of the urban population could only afford the basic goods and services basket typical for that food consumption group. If we add to this the not insignificant share of the population who live marginally above the poverty line and hence on the edge of poverty and vulnerable to minor economic fluctuations, the phenomenon of mass poverty in Yemen becomes even more pronounced".

In spite of some adverse economic trends and population growth, poverty since 1998 has slightly improved. However, the latest economic reform measures will add an additional burden on the poor. With regard to the urban context, rural-urban migration and lack of employment opportunities result in an accelerated urbanization of poverty. This trend is likely to continue; while rural poverty will not decrease substantially in the short term, urban poverty, especially above the food poverty line, is on the rise.

"...It may be noted that income poverty is a one-dimensional measure of poverty, strewn with measurement problems, and what appears as generalized poverty in Yemen is no more than a statistical artefact based on the choice of the poverty line..." According to the National Poverty Survey (NPS) 1999, more than 58% of the population considered themselves poor or extremely poor, falling within the lowest income quintiles. Many poverty indicators such as illiteracy, school drop-out, health and nutrition point towards mass poverty in Yemen. In urban areas, these are often less dramatic because population concentration facilitated improved access to social infrastructure.

Summary of Conclusions

Are the project towns poor in general and/or is the majority of the population poor?

- None of the surveyed towns has been selected on the basis of poverty data; nonetheless, all towns show poverty characteristics, based on income and expenditure data, well above national and urban values; no data is available to verify the position of survey towns within national urban ranking
- More than half of the population of the towns is poor

Do the project measures focus on specific poor groups within the towns?

- Infrastructure provision does not follow any poverty related locational pattern; there are no clearly identifiable poverty pockets within the urban boundaries
- Due to the substantially higher cost of alternative water sources, public network provision specifically benefits the poor independently of their location, provided they are connected
- Water supply interventions show no diversification in technology choices, due to operational and environmental considerations, but in large part also due to community acceptance aspects; there seems to be no wide range for cost-effective options in urban areas

Do the poor get a fair share of water?

- If a low consumption pattern (up to 10 cbm/month) is considered as household poverty indication, then in average at least 60% of the clients are poor and no restriction is visible
- In consequence, the quantity share of overall water sold is low, in average around 35 – 40%; this may partly be triggered by purposely reduce consumption in order to remain in low tariff brackets
- Since access for basic needs quantities is facilitated by low tariff brackets, the poor have a fair share of the water sold by the utilities

Is water expenditure an acceptable burden for the poor?

- Household expenditure on water is quite low and neglectable compared to payments for qat and tobacco; there are no indications, even in the lowest income quintile, that water cost is unbearable

Are water tariffs pro-poor?

- There is no correlation between overall poverty level of the towns and their tariff levels; since the poor are poor everywhere, acceptance of water cost seems to respond to complex considerations
- All towns provide for special tariffs for “lifeline” consumption (up to 10 cbm/month) targeted at the poor, but with a wide range which again is not related to the towns’ overall poverty
- The block-tariff system is definitely pro-poor, but could be further targeted, since large consumers reap considerable windfall reduction on their water bills

Is there additional cross-subsidy potential for poor households?

- Prevailing water tariffs are the results of sometimes controversial local consultation processes; not all tariffs are cost covering, some have not been adjusted for a long time
- Client structure in the utilities is mainly consisting of small users (up to 10 cbm/month); no significant number of commercial clients to carry the cross-subsidy burden
- Consumption structure of the utilities shows that main cross-subsidy potential lies within the domestic users above 10 cbm/month; this requires careful approach to tariff adjustments

Sector salient features

- **Water users and the MDG relevance**
- **Water demand and health impact**
- **Understanding Yemen's water cycle**
- **Expected urban growth**
- **Water demand and supply pattern**
- **Real cost of water and the Yemeni scenario**
- **Water sector benchmarks**

Water users and MDG relevance

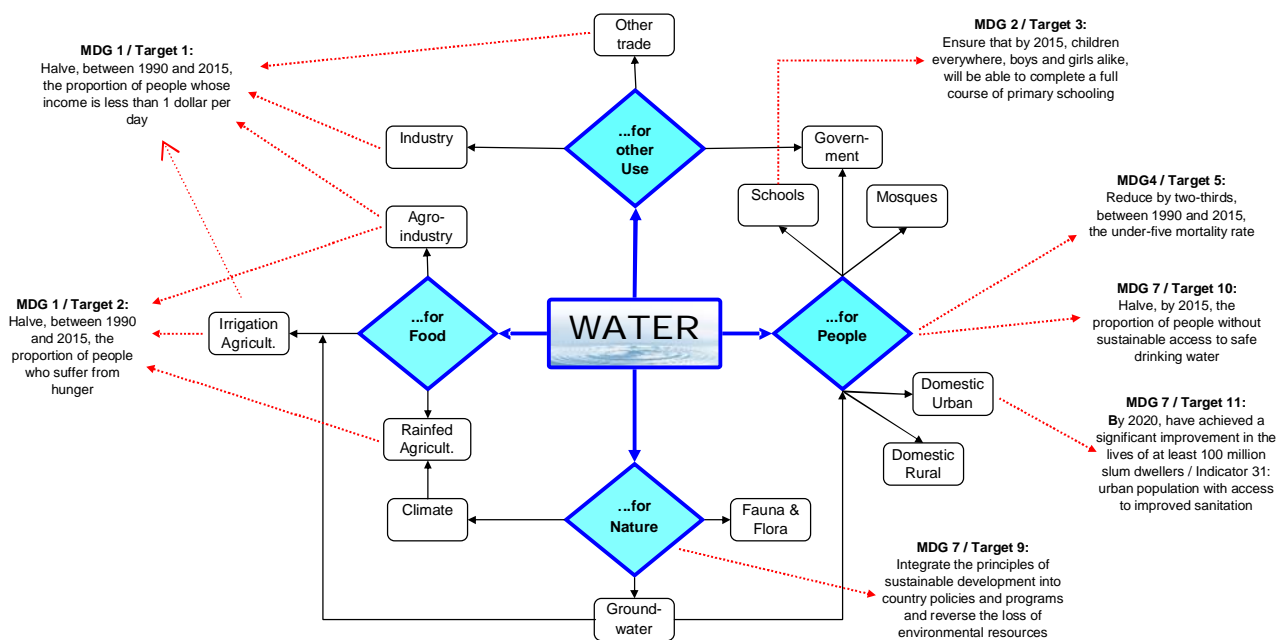

There are competing demands regarding the use of water. Although domestic use has a manifest priority in national policies, integrated resource management needs to encounter a healthy and sustainable balance of resource allocation. Availability of water has a significant bearing on the achievement of various MDGs. Although the definition of the specific water supply target is not clearly pro-poor, it is evident that lack of water affects the poor more severely.

With regard to **Goal 1 / Target 1**, employment and income generation in industry, especially agro-industry, needs water. With regard to **Goal 1 / Target 2**, fighting hunger on a sustainable basis is not possible without local food crops, and there is no agriculture without water. With regards to **Goal 2 / Target 3**, proper schools, especially those attractive to girls, need to be equipped with adequate sanitary facilities. **Goal 4 / Target 6** is directly related to improvement of hygiene and reduction of water related diseases. **Goal 4 / Target 10** directly demands availability of clean drinking water in the family dwellings. **Goal 4 / Target 11** calls for safe sanitation with special emphasis on urban poor. Finally, **Goal 7 / Target 9** focuses on the sustainability of natural resources, among which water plays the most prominent role.

Water demand and health impact

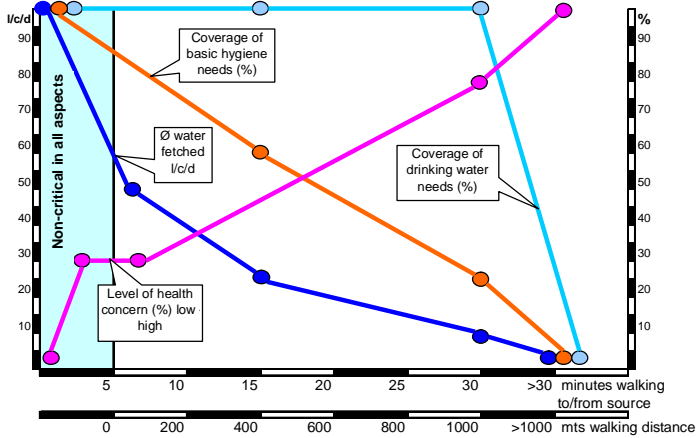

Source: WHO/SDE/WSH/03.02, WHO Geneva 2003

Although drinking water is a matter of survival, there are indications that the ease of access to water sources has a significant bearing on the water quantity consumed by the households.

Independently from the reliability of available water supply service, the average quantity of fetched water declines with walking time and distance.

Non-critical for all household needs (drinking, cooking, bathing, washing) seems to be a distance to source of up to 100 mts only.

At a distance beyond 1000 mts, the basic water needs (7.5 l/c/d at average temperature and low physical activity) are apparently no longer attended sufficiently. A household water supply of 20 l/c/d is generally considered as a threshold for obtaining measurable health impacts. **This is met in all urban projects.**

Understanding Yemen's water cycle

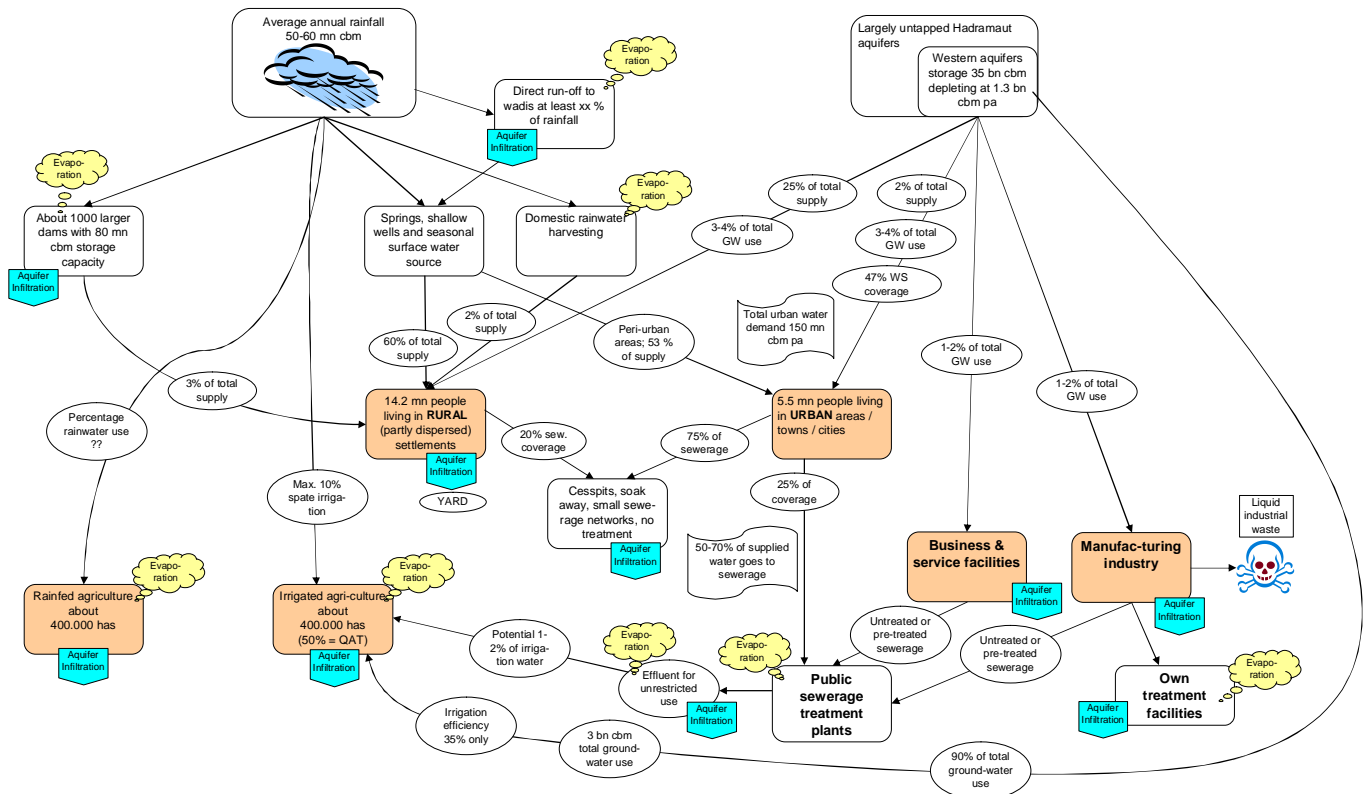

Expected urban growth

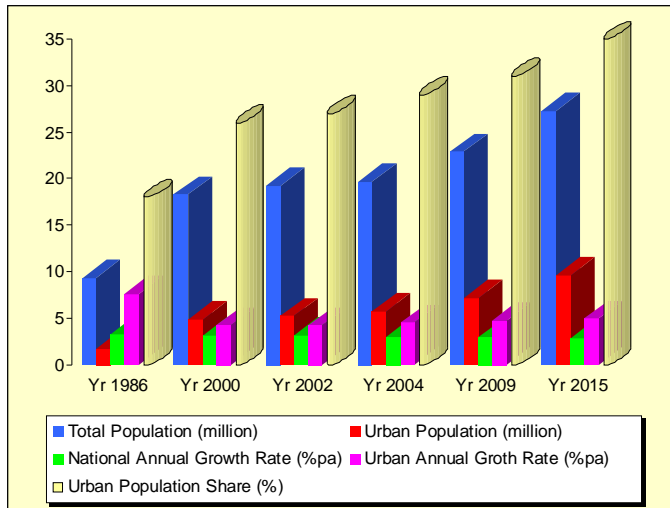

Although Yemen is still a largely rural society, the expected urban growth will have triggered the urban water demand till 2015 by 50% as compared to 2005. When trying to achieve the MDGs for water supply, past poor implementation capacity of the rural water sector has to be taken into account. Most of the service coverage increase of the past years has been reached in urban areas.

Water demand and supply pattern

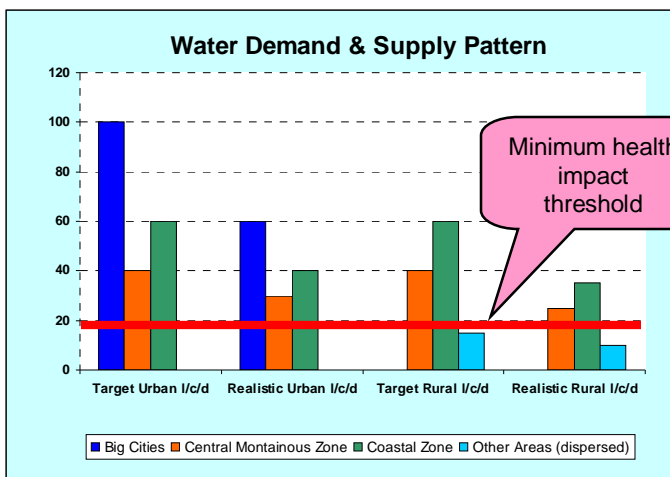

The targets set for urban and rural per capita water consumption are challenged by increasing water scarcity and decreasing quality. It can be assumed that for dispersed rural settlements the minimum water availability required for obtaining some measurable health impact may not be obtainable.

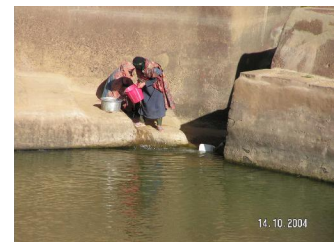

Real cost of water and the Yemeni scenario

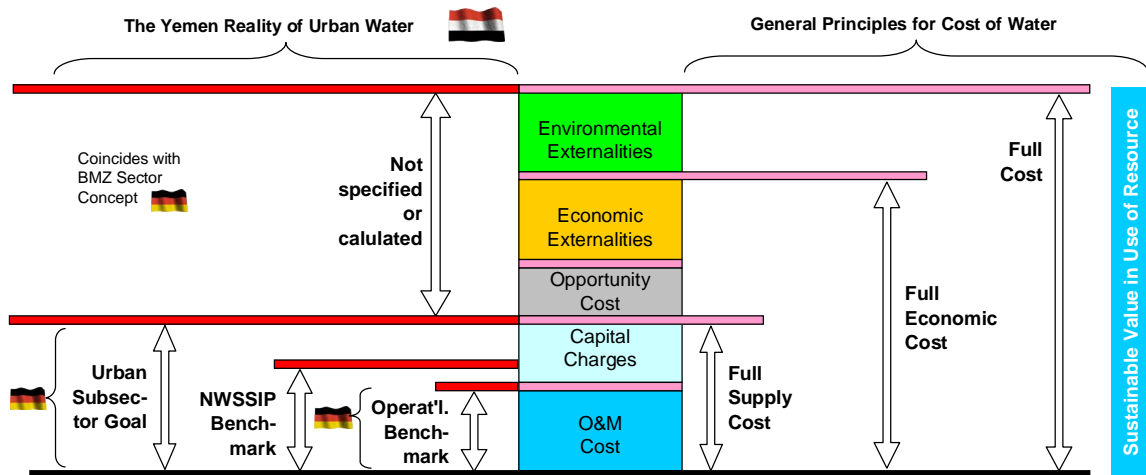

Source: Global Water Partnership TAC Background Paper No. 2 (Water as a Social and Economic Good) / own elaboration

The 1996 BMZ sector concept establishes a minimum benchmark for cost coverage (at least operation & maintenance cost) which is now basically reached by all urban utilities in Yemen; at the same time, the urban sub-sector goal aims at reaching full cost coverage (full supply cost). The National Water Sector Strategy and Investment Program (NWSSIP) puts the performance mark at O&M cost plus depreciation of electro-mechanical equipment, which in total is estimated at about 70 – 75% of full supply cost. Although there is a high degree of compliance with German sector goals, cost coverage as a whole is not providing enough revenues for a sustainable resource use.

Water sector benchmarks in Yemen

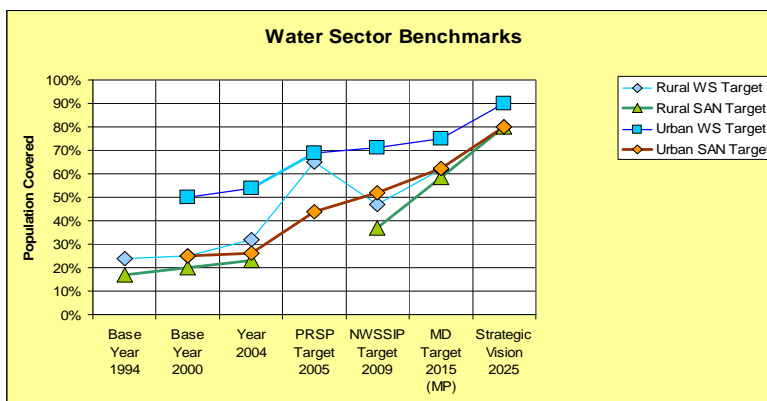

It is worth noting that figures for achieved service coverage in the various policy documents show a considerable spread. NWSSIP final document indicates national water coverage at 32% and national sanitation at 21%; the 2002 base figures are 47% urban water, 25% urban sanitation, rural water 25% and rural sanitation 20% (2003). The World Bank CWRAS uses the same figures. The latest PRS progress report states that urban water coverage has reached 62.4% in 2004, while rural coverage for water is up to 33.8%. Urban sanitation is said to cover 38% in 2004, no sanitation figure is given. In contrast, the MDG country report indicates for 2004 the following coverage: urban water 54%, rural water 32%, urban sanitation 26%, rural sanitation 23%. The info sources are apparently not the same. With exception of the PRS report, all sources indicate a rather moderate coverage increase.

POVERTY INDICATORS OF SURVEY TOWNS

- **Poverty profile of survey towns**
- **Household expenditure pattern**
- **Average household income**
- **Per capita food poverty line**
- **Income quintiles and water expenditure**
- **Sources and cost of water**

Poverty profile of survey towns

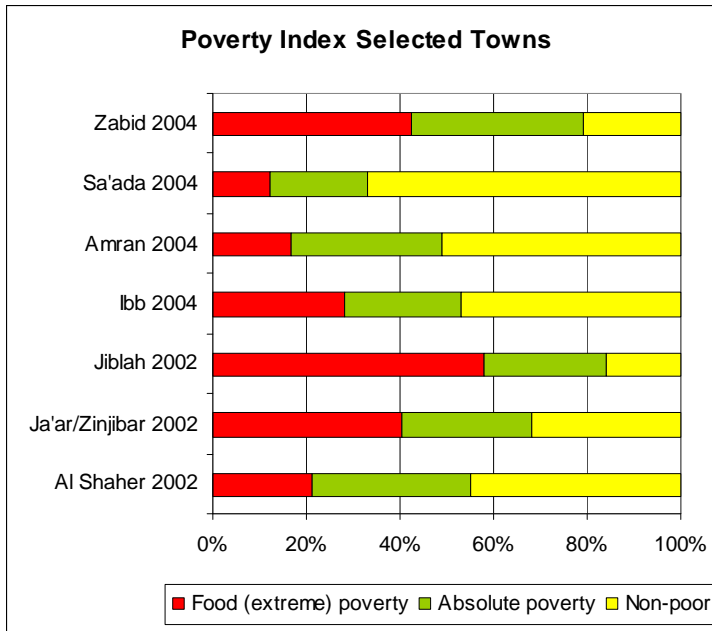

There are substantial differences in the poverty structure of the different towns. Nonetheless, with exception of Sa'ada, absolute poverty affects up to or well above 50% of the population. Food (extreme) poverty also affects all towns in a wide spread of proportions, in many cases doubling the national (27%) and even the urban (xx%) average.

In spite of the fact that the town selection process of the past has not specifically prioritized on poverty aspects, it can be stated that the survey towns as a whole belong to the poorer group of urban centers.

Household expenditure pattern

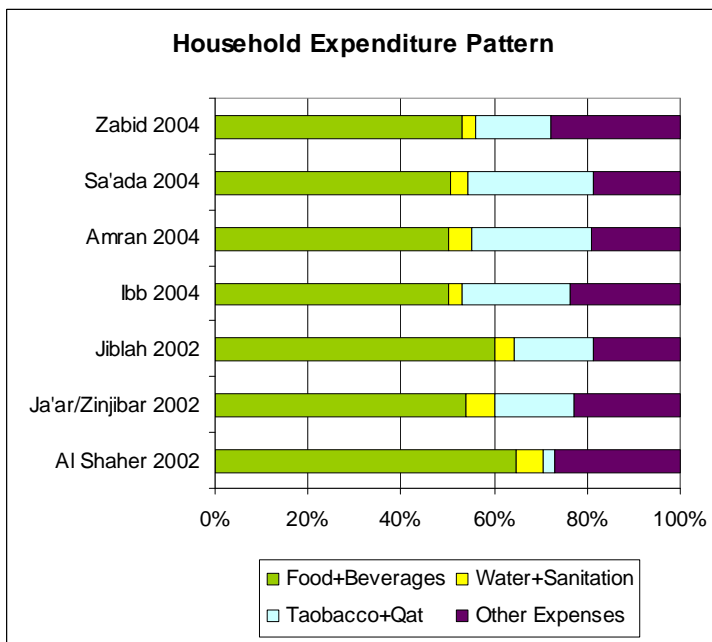

It is interesting to note that the differences in the poverty structure of the different towns are not equally reflected in the household expenditure pattern, which is much more balanced over time and location. The most relevant fact is that expenditure for water & sanitation is an almost neglectable cost item and is largely exceeded by expenses for tobacco and QAT.

Average household income

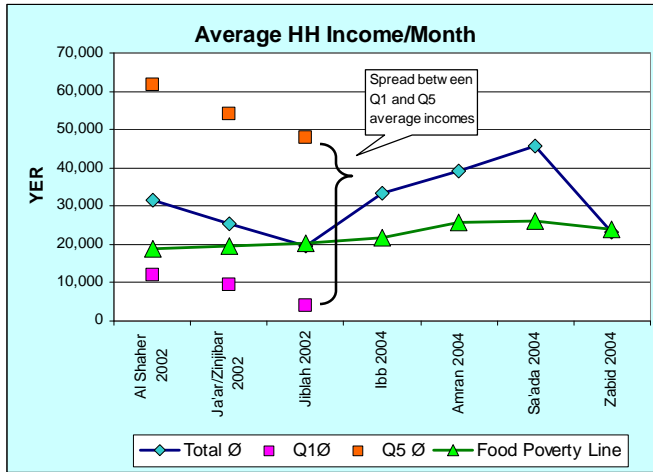

The graph shows the average nominal household income (YER/month) and the average income in quintiles 1 (bottom group) and quintile 5 (top group). In Jiblah and Zabid, the average income can barely meet the official food poverty line established for the average household size. Families in the lower quintiles (Q1 & Q2) in all towns appear to be in permanent nutritional crisis, since the average spending on food is only in the range of 50 – 53% of total expenditure.

(Income data broken down by quintiles are not yet available for the 2004 survey towns)

Per capita food poverty line

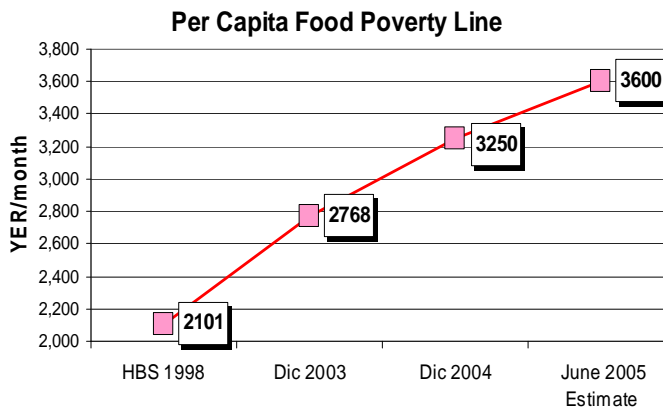

Graph shows the inflation of the official food poverty line since the 1998 HBS (YER/month). The increase from 2003 to 2004 alone was 17.4%. Food prices have generally shown a high degree of volatility, in part due to imported food items, and their inflation was mostly located well above the corresponding overall consumer price index (CPI). The June 2005 estimate was done before the recent economic reform measures and it can be assumed that food prices will experience a major upward development in the coming months, in spite of the government's efforts related to price control measures.

Income quintiles and water expenditure

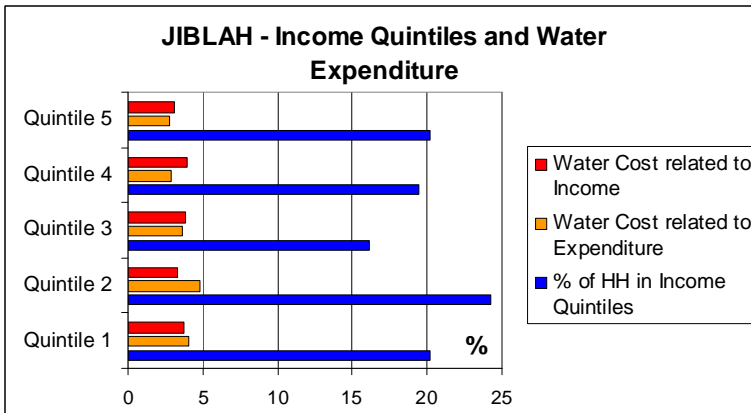

In spite of being the poorest town of the sample and representing a high percentage in the lower income quintiles, the household water cost does not show a substantial deviation between the different income quintiles. In other words, the higher overall poverty of the town has not inflicted, internally, a higher proportional water expenditure on the poor.

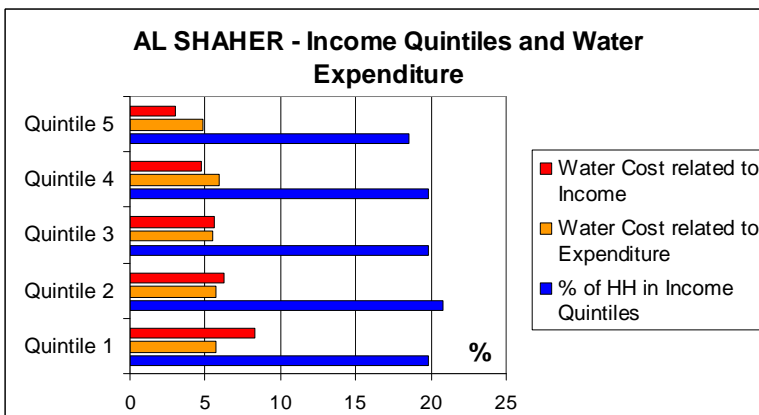

The relative household water expenditure shows some deviation between the different income quintiles, but the lowest quintiles have only a slightly higher expenditure rate. In other words, poorer population groups still have a similar expenditure share for water than the non-poor groups, related to their overall expenditure or income.

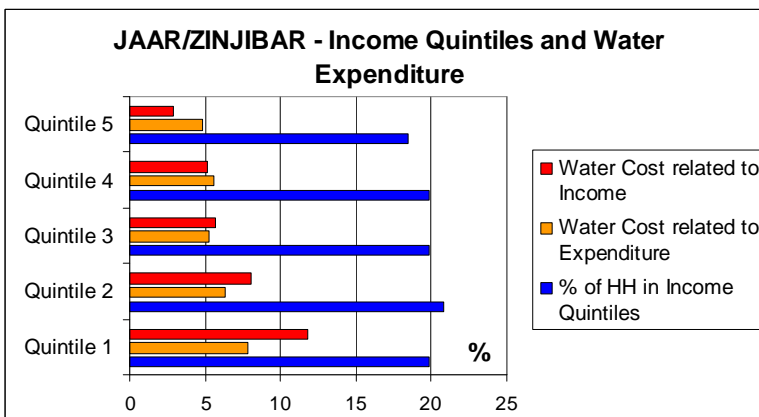

The household water cost shows a notable deviation between the lowest and highest income quintiles, and the lowest quintiles manifest a tendency for overspending in relation to their income. In other words, poorer population groups have a higher expenditure share for water than the non-poor groups, related to their overall expenditure or income.

Sources and cost of water

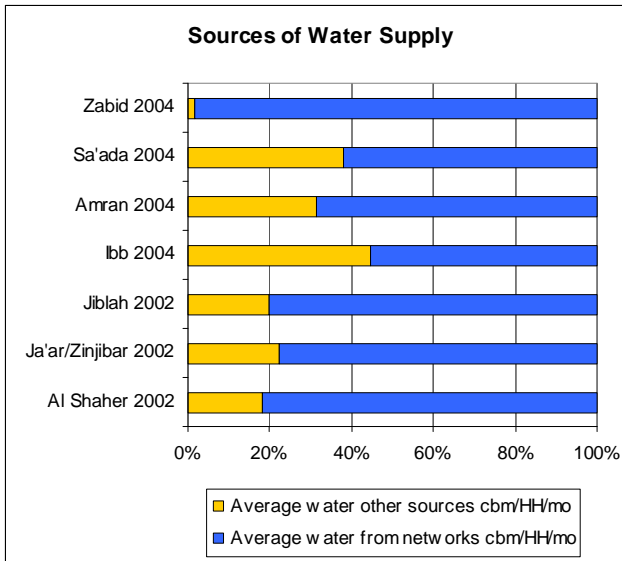

Although networks are by large the main source for overall household water supply, often drinking water is complemented from alternative sources, mainly due to water quality concerns or network delivery deficiencies.

In both Zabid and Ibb, high network coverage coincides with its use as main source for drinking water. This may be due to high poverty rates which leave little room for alternative and more expensive sources such as water trucks and bottled water. Water networks are thus a pro-poor investment. The high usage of alternative sources in Amran and Sa'ada may relate to higher average incomes, but also points at low network performance / water availability and/or quality. 1)

1) Above graphs reveal some contradictions regarding figures given for network supply of household water and drinking water, especially in the case of Ibb.

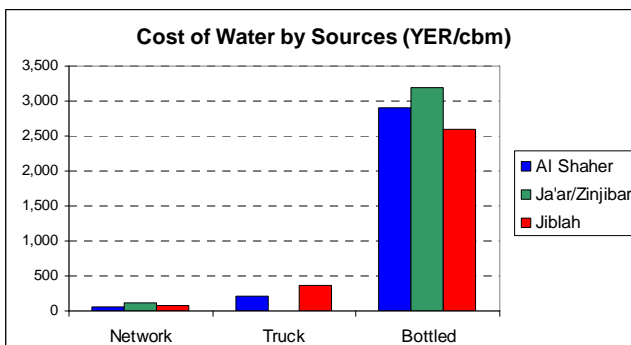
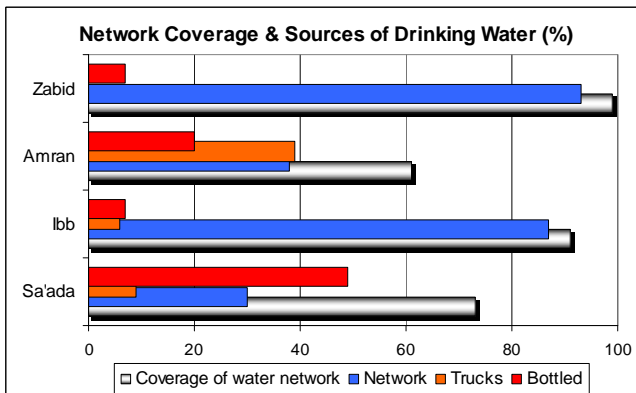

Filtered/bottled water is purchased for drinking / some cooking purposes. Low quality network and truck water require additional expenses for purification or boiling. The single most relevant poverty impact is thus achieved by extending networks to un-served areas with good quality water supply.

UTILITY OPERATORS AND PRO-POOR WATER TARIFFS

- **Client base of utilities**
- **Consumption structure of utilities**
- **Range of prevailing lifeline tariffs**
- **Water tariffs and pro-poor cross subsidy potential**

Client structure of utilities

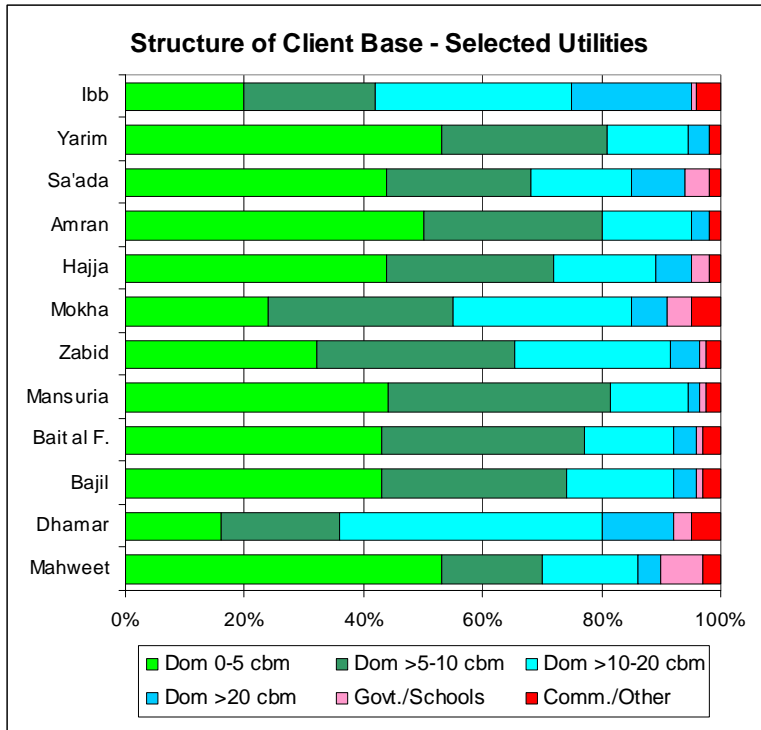

Most of the domestic clients are small consumers in the range of up to 10 cbm/month/HH. All households are making use of the “lifeline” tariffs of the first two brackets. Due to the block tariff system design, considerable savings can be made by the larger consumers, because they benefit from all “subsidized” tariff brackets. The poverty targeting of the cross-subsidy scheme could thus be substantially improved. This is all the more important due to the rather low number of non-domestic clients.

The graph clearly shows that the networks primarily benefit the small users, which in most cases are also the poorest client segment.

Consumption structure of utilities

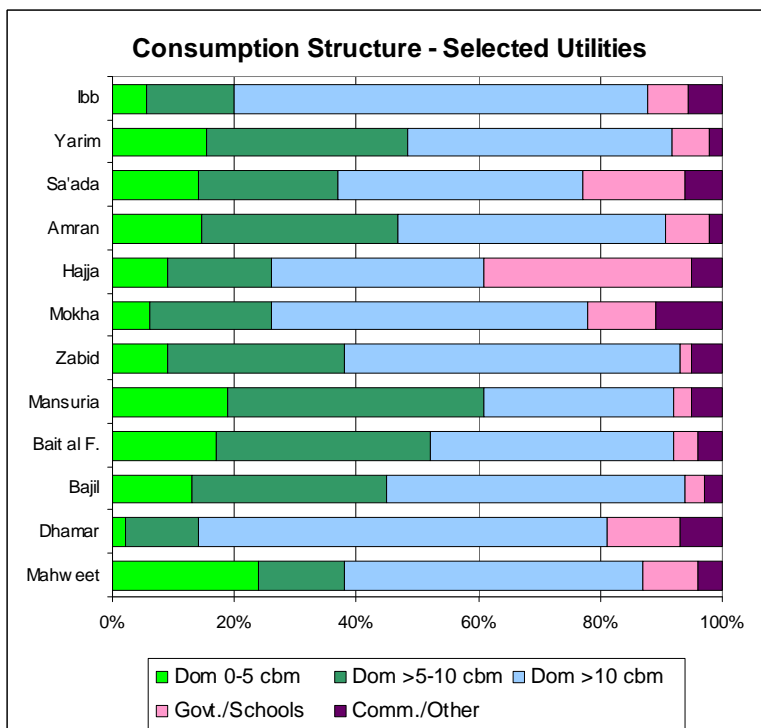

As can be expected, the actual water consumption of the “lifeline” tariff clients is much lower than their representation in the client structure, the average at some 37% of all water sales.

The consumption of governmental and commercial facilities is generally low.

Information on the revenue structure, which would support this thesis, could not be obtained yet.

Range of prevailing lifeline tariffs

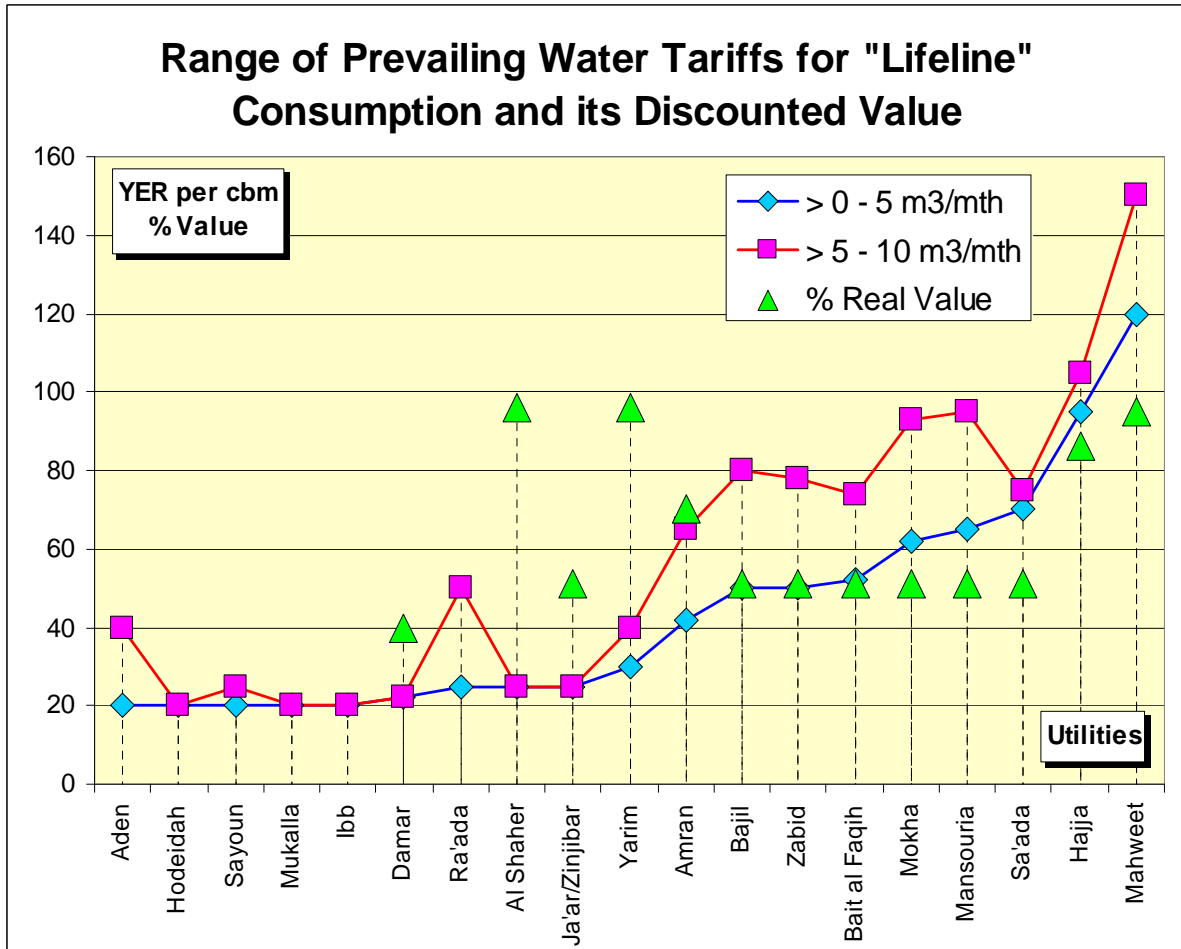

The graph shows the valid tariffs in April 2004. Low end tariffs (≤ 5 cbm consumption bracket) range from 20 to 120 YR per cbm, while high end tariffs (5-10 cbm) range from 20 to 150 YR per cbm. Many utilities face substantial real value loss of revenue from tariffs due to accumulated inflation. In one case (Dhamar), its value is only 40% compared to date of introduction (for simplicity, a 1% monthly YER inflation is assumed).

The graph gives a rather comprehensive view on the variety of local tariffs for "lifeline" domestic consumption, including large urban centers and small towns in rather rural setting.

Water tariffs and pro-poor cross subsidy potential

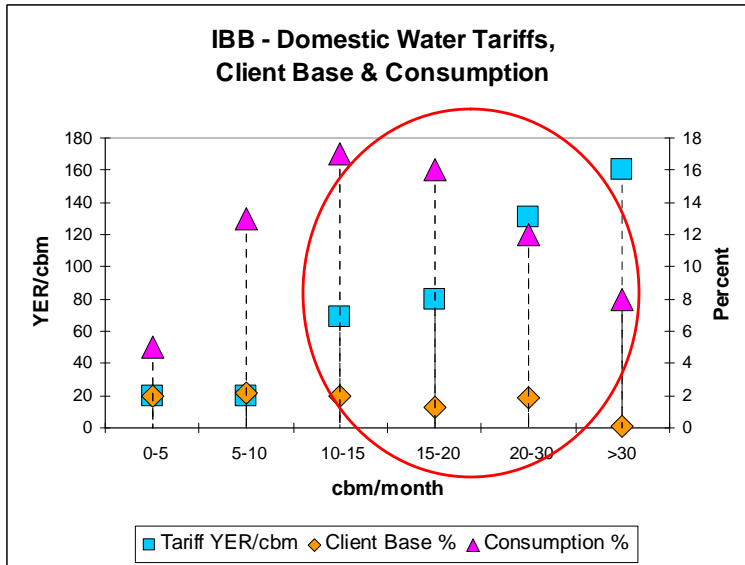

In IBB for example (one of the utilities with the lowest tariffs countrywide), out of each 1000 clients, 580 benefit unnecessarily from lifeline consumption subsidy (< 10 cbm/month): 330 are in the 10-20 cbm range, and 200 in the >20 cbm range. The large consumers benefit throughout various tariff ranges. Clients consuming up to 30 cbm/month are actually saving about 43% on their water bills, consumers of up to 20 cbm/month still about 41%, as compared to be paying maximum tariff for the total consumption.

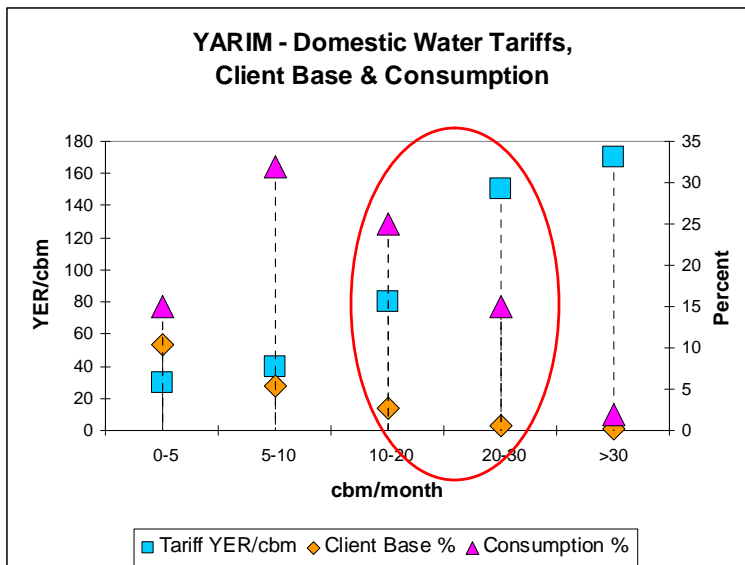

Tariff levels do not coincide with poverty levels: Mahweet, one of the poorer towns, has the highest tariff level in the country. It appears that the largest cross-subsidizing potential lies mostly within the domestic users consuming > 10 cbm/month, because they agglutinate a considerable number with high consumption volume.

Consequently splitting the first 10 cbm consumption into 2 tariff groups and eliminating the subsidy portions for large consumers would substantially increase revenue without affecting the poor.

TECHNOLOGY CHOICES

- **Pro-poor choices for water supply**
- **Pro-poor choices for sanitation**
- **Results of study 1 (Ecosan)**
- **Results of study 2 (Alt. Sanit. Systems)**

Pro-poor technology choices for water

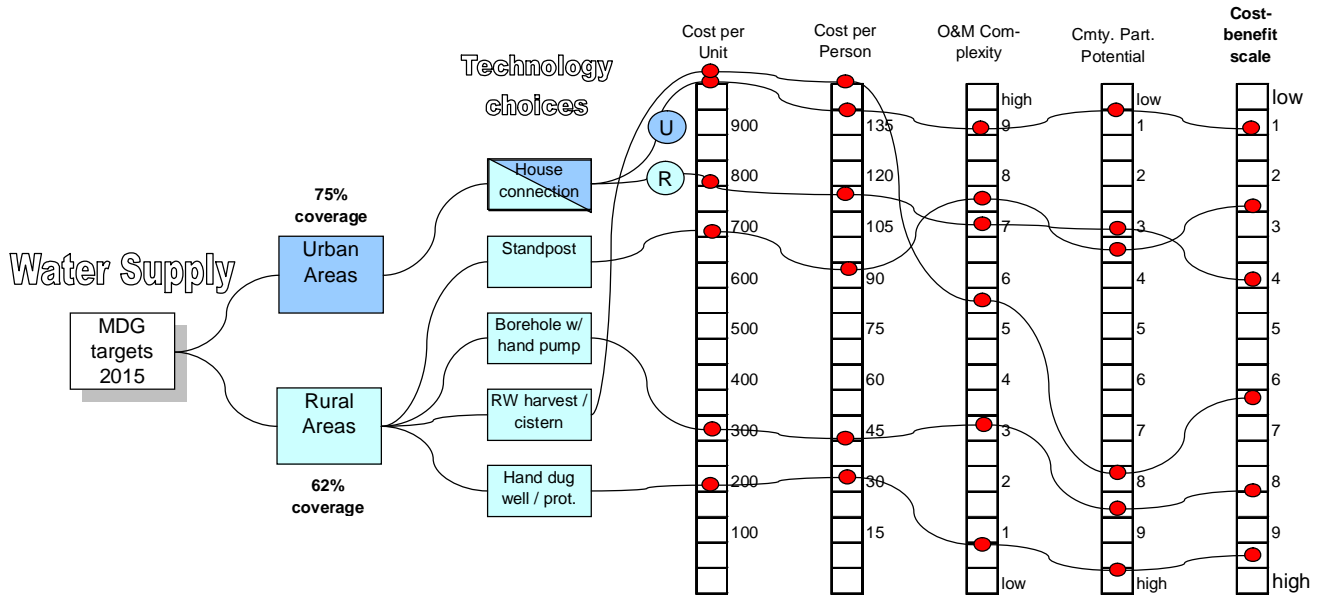

Complex urban supply systems for large and sometimes high density service area usually require investments beyond networks, such as head-works like deep wells, pumps and storage tanks, water treatment, etc. and demand quite some technical / administrative capacities. At the consumer end, there is usually little acceptance of anything else but formal house connections; this coincides with utilities' aim to guarantee technical and managerial system safety.

Above graph shows (based on the MDG needs assessment) some of the interrelations between technology choices and the inherent cost and operational aspects. The most frequently implemented solution for urban areas (central system plus house connection) seems to have some unfavorable conditions (rather high unit cost / high O&M complexity / low community participation potential), while there is a clear advantage in being able to professionally manage operations at the utility level. On the other hand, there seems to be design optimization potential with consequently lower investment and recurrent cost.

Technology choices and their acceptance by the community are influenced by cost and resulting tariffs, resource availability, and water quality & specific location of the service areas in the urban context. Above presented cost-benefit ratio does not consider factors such as opportunity costs, environmental externalities such as resource handling etc., which may influence technology choices further. The wider scope for cost-effective solutions (high on the cost-benefit scale) is to be found in rural areas.

Pro-poor technology choices for sanitation

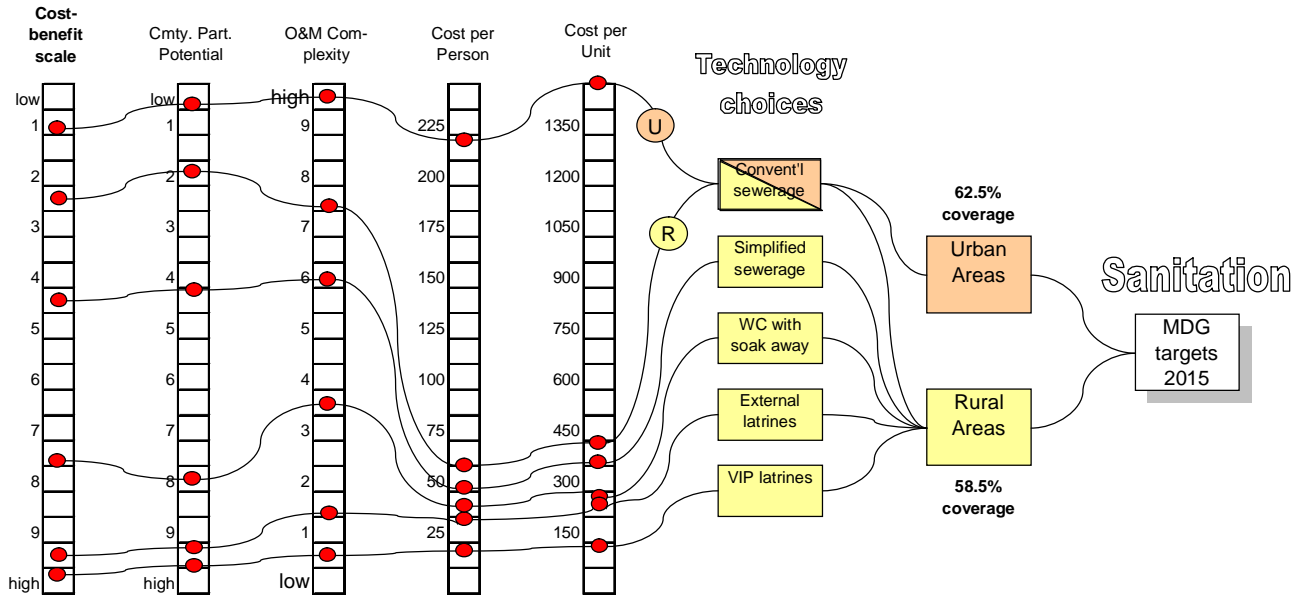

Complex urban sanitation systems for large and sometimes high density service area usually require investments beyond pure networks, such as pumping stations and treatment plants. These demand quite some technical / administrative capacities. At the consumer end, there is usually little acceptance of anything else but formal house connections; this coincides with utilities' wishes to get technical and managerial system safety, but implies low community participation potential in operations. Above refers to the urban core, while low density peri-urban areas may be served by decentralized or on-plot facilities. Nonetheless and given the speed of urban growth, sewer mains and STPs should be dimensioned for future connections and thus additional load.

Technology choices and their acceptance by the community are influenced by cost, resulting tariffs, expectations of time of connection for particular areas and environmental concerns. Discussions regarding alternative sanitation systems have so far provided no real options for comprehensive urban sewerage other than central systems and house connections. On the other hand there are apparently some design optimization potentials for centralized systems which could well reduce investment and recurrent cost.

Above graph shows (based on the MDG needs assessment) some of the interrelations between technology choices and the inherent cost and operational aspects. It appears that the broader range of cost-effective alternatives are to be found in rural areas.

RELEVANCE OF URBAN SUB-SECTOR

- **Urban share in NWSSIP**
- **Urban share in MDG needs assessment**

Urban share in NWSSIP

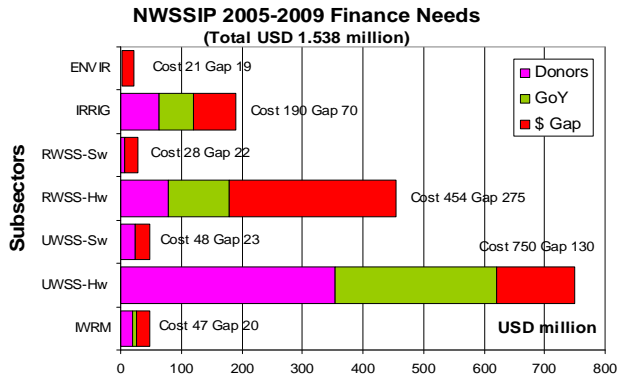

Although urban population has only a xx% share in total population, interventions in the water and sanitation sub-sector have a clear bias on urban areas. In the National Water Sector Strategy and Investment Program (NWSSIP) NWSSIP, urban investments and capacity building efforts represent 52% of total cost. This is due to a larger number of planned projects, larger specific cost, higher population concentration and last not least, to the higher absorptive capacity of urban utilities as proven over the past years.

When analyzing the NWSSIP's urban finance scenario, it is also obvious that there we find the largest portion of effective / committed / earmarked donor funding and the corresponding local budget; at the same time, the non-defined share (finance gap) is rather small.

NWSSIP 2005-2009 Funding Scenario

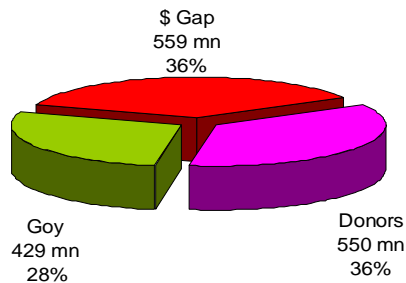

NWSSIP 2005-2009 Subsector Finance Shares

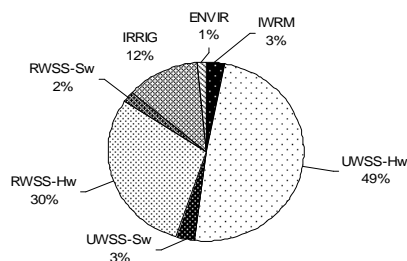

Urban share in MDG needs assessment

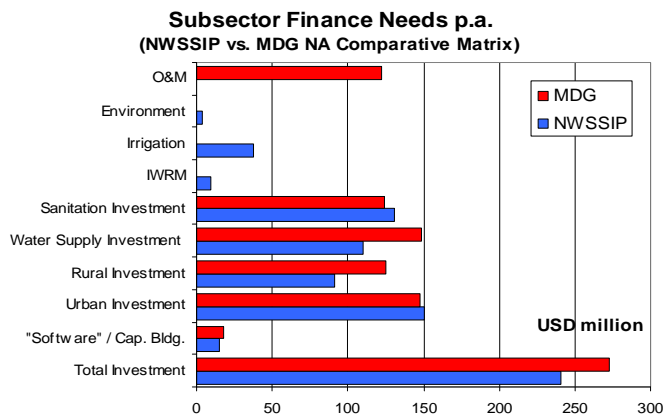
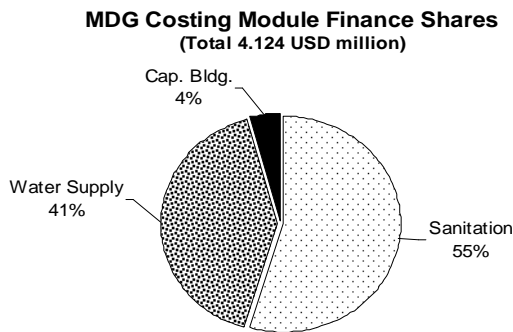
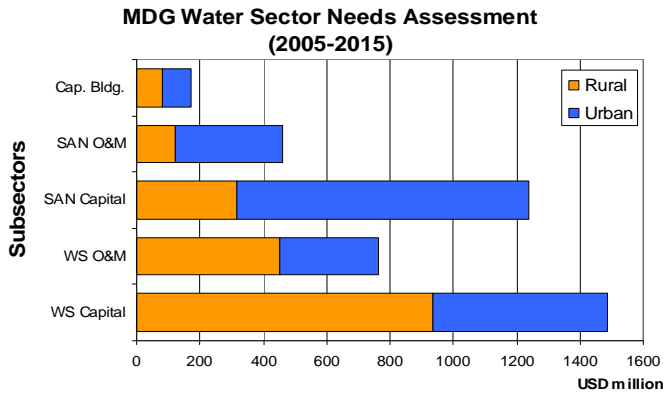

NWSSIP and MDG needs assessment have different approaches in some specific components:

Firstly, MDG ignores the irrigation sub-sector which is however included in the more sector strategic NWSSIP document. Secondly, MDG assigns a much higher investment portion to the rural water supply sub-sector, by largely ignoring present implementation capacity constraints (which was considered in NWSSIP and led to a downscaled rural target). Thirdly, MDG includes O&M cost for all of the W+S infrastructure, which was purposely ignored in NWSSIP; nonetheless, in both approaches the cost coverage of O&M by users is basic principle. Fourthly, MDG is not including price escalation, while NWSSIP includes a moderate foreign exchange inflation, but which is also grossly underestimated.

After a considerable upward turn for rural water supply, the urban sector still maintains its priority fund absorption position in sanitation investments. All estimates are derived from MDG target application and do not consider available funding or absorptive capacity.

In spite of these conceptual differences, the established annual investment shares for water supply, sanitation, rural and urban are very much congruent.

REMARKS AND OPEN QUESTIONS

- **Pro-poor project targeting**
- **Implementation constraints**
- **Recurrent costs**

Pro-poor project targeting

- Water MDGs or PRS targets do not specifically focus on the poor
- Better targeting hampered by non-availability of location-specific poverty data
- Urban poor mostly not clustered in urban context
- Present poverty monitoring systems do not provide project relevant data
- No specific pro-poor capital allocation has taken place

Implementation constraints

- Rural water focus hampered by poor absorption capacity
- Pro-poor specific projects often collide with implementation efficiency demands
- Appropriate norms and standards lack acceptance
- Lack of social participation in planning and implementation
- Sector institutions highly dependant on external consultants and contractors
- Lack of local contractor promotion (by sizing of tender lots)

Cost recovery

- Recurrent cost impact concern often neglected as government covers the investment cost (full depreciation via not mandatory and debt service not factored in)
- Inappropriate designs trigger future high O&M costs
- Cross-sector water transfer (water rights/raw water cost) not factored in
- Cost-sharing approach becomes a common demand in social services and may overload communities
- Tariff cross-subsidization (block-tariff-system) not sufficiently pro-poor
- Tariffs not gender-sensitive (no specific consideration of women-headed HH)